

NOXEL

SOLUTION YOU CAN TRUST

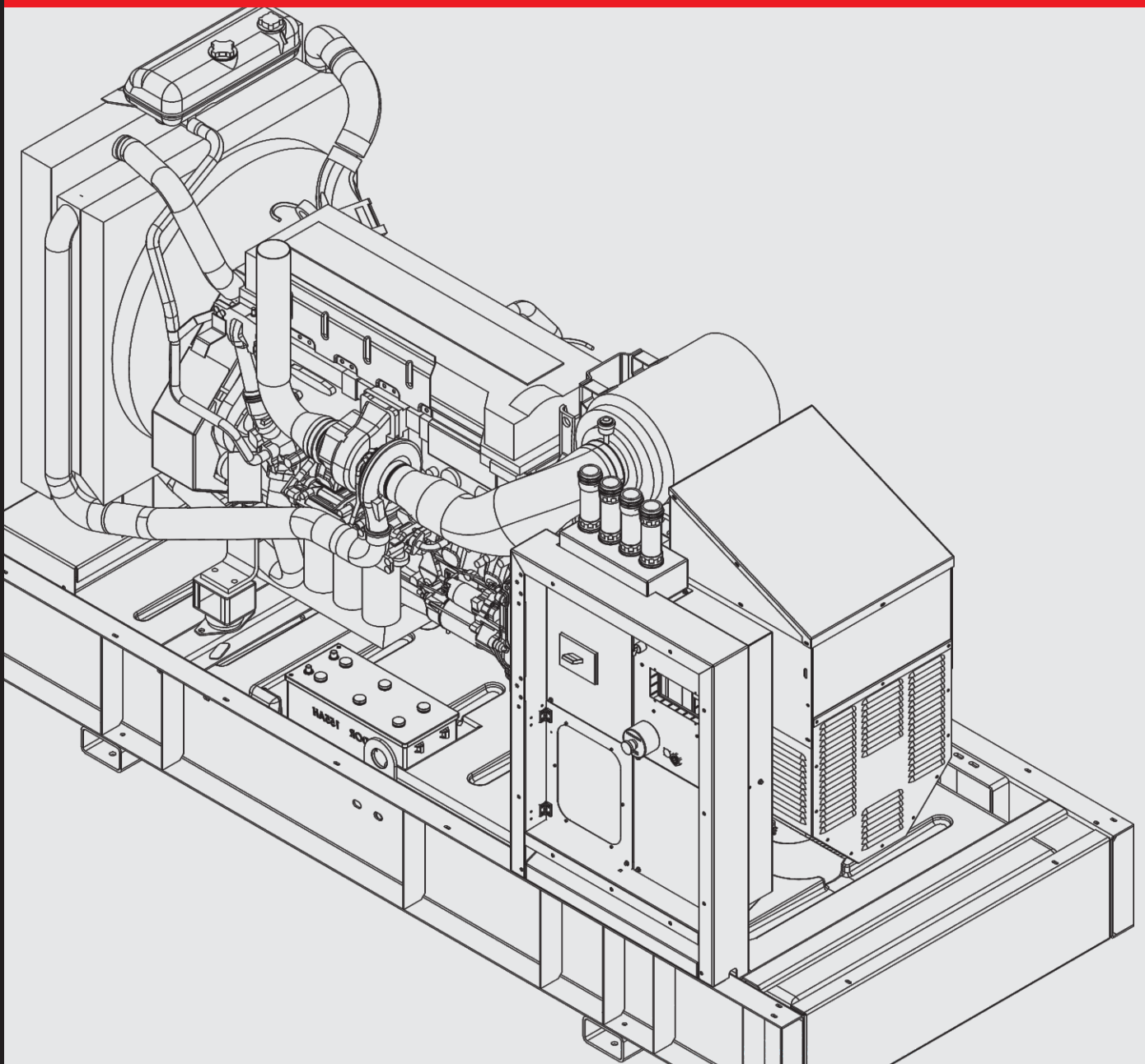

MODEL : NW 450-400 KVA



400 Series NW 450-400 KVA Gas Engine - Electropak

The new NW 450-400 KVA engine has been developed using the latest engineering techniques and builds on the strengths of the already very successful 400 Series family and addresses today's uncompromising demands within the power generation industry. Developed from a proven heavy-duty industrial base these products offer superior performance and reliability.

The NW 450-400 KVA is a turbo charged and air-to-water charge-cooled, 6 cylinder gas engine which offers a choice of temperate or tropical cooling. Its premium features provide exceptional power-to-weight ratio resulting in exceptional gas consumption.

The overall performance and reliability characteristics makes this one of the prime choices for today's power generation industry.

HIGH QUALITY STEEL AND PAINT PROCESS

The canopies are made of high quality steel and are completely powder coated. The paint is a three step process ensuring protection against erosion, scratching, and corrosion. Further we give a 5 year warranty on these enclosures.

ADVANCED WATERPROOFING AND DUST PROOFING

The control panel, service doors and canopy board adopt a waterproof design and effectively stop rain and dust intrusion.

EXCELLENT ANTI-VIBRATION DEVICES

Anti-vibration mountings between the engines, alternators and the base significantly reduce the vibrations during operation, ensuring stable operation. All movable devices are fixed firmly, and therefore help reduce vibration.

ENHANCED SAFETY

INFORMATION SAFETY

The machines are equipped with monitoring system, helping monitor the operation at real time. We provide DSE-7420 control module for your operation.

ELECTRIC SAFETY

The double protection for the cable connection panel lowers the probability of leakage caused by unintended touch or water intrusion.

Three-dimensional CABLING design for all the generator cables, providing reasonable, accurate and perfect protection.

Automatic turn-on circuit breaker with under-voltage protection system inside maximally avoids mistakes.

Automatic control module for multi-directional monitoring meets multilevel demands and considerate protection of or for customers.

OPERATION SAFETY

The radiator and high-voltage parts are guarded to avoid accidents caused by touch.

The control panel is lockable. Current changeover switch, voltage regulator and circuit breakers are installed behind the door.

Anti-vibration rubber mounts are installed in the two sides of the doors to avoid damage to the machines when open the doors. Lockable gas filling cap.

ENVIRONMENTAL

The noise level can be reduced by 15-35dB(A) through multiple noise control devices, which enables quiet operation and has no effect on daily life. This feature makes our gas generators ideal for use at night, in residence, office and other environments sensitive to noise.

Cleaner exhaust, less effect on the environment, even in outdoor application.

SPEAR GASOLINE

TANK DESCRIPTION AND FUNCTION

Extended Diesel tank has both maintenance and performance uses. This tank is designed to allow the generator engine switch from Wet Gas to gasoline for maintenance reason that occurs every 2000 hours. This solution lubricates engine parts which improve generator performance and extends its total life span. It also enables the system to use gasoline In case of emergency and lack of natural GAS to pass the critical event.

POWERFUL ENGINES

Adopts world-famous engines, with low noise and low emission. Rigid structure ensures lowest vibration.

Common rail system: (for some models) significantly lowers the combustion temperature, and also leads to cleaner exhaust.

EXCELLENT SILENCERS

Silencer and muffler pipe system dramatically reduce the noise during operation, and therefore cause less effect on daily life.

HIGH QUALITY SOUND ABSORBING MATERIAL

The interior is lined with new type fire retardant and sound absorbing material. The door is airproof with rubber seals specific for car doors use only, which helps absorb massive noise and heat during the operation.

FULLY-ENCLOSED NOISE REDUCTION

Besides applying airproof rubber seals around the doors, the concept of noise reduction has also been fully integrated into the inlet/outlet and other aspects.

EASY TO OPERATE

CONTROL SYSTEM

Micro-processor cored digital system.

Multiple languages for option, automatic control.

Connected with mains through ATS, which can help realize automatic transfer between the mains and the generators. Also, multiple generators can be paralleled for bigger power need.

HUMANIZED DESIGN

The oil drainage pump is located in the side door for easy operation.

New type waterproof door lock is easy to lock and open.

Clear labeling in visible positions, providing adequate information, safety presentation and convenience for operators. The labels are made of advance materials, featured with excellent high-temperature resistance, rainproof and weatherproof performance.

CONVENIENT CONNECTION

Terminal connection lugs (L1, L2, L3, and LN) make connection and wiring more simple and well-ordered.

Emergency stop provides convenient operation in emergent situation and when servicing.

EASY TO TRANSPORT

The machines below 1000kVA have holes for forklift and dragging in the base for easy transport.

Lifting eyes located on top of the canopy make easier move by cranes.

EASY TO MAINTAIN

The daily maintenance work can be performed on both sides of the machine, and wide door allows you easily get in touch with the machine.

An integral base drainage outlet located at the bottom of the machine makes easier regular maintenance.

For generators above 300Kva, a ladder for climbing is equipped. It makes easier to check and service.

- 1 Year / 10,000 Hour Limited Warranty(Whichever comes first)
- Automatic Starting System(to work with Automatic Transfer Switch)
- Battery Charging Alternator
- Critical Muffler Included on Enclosed Units Available as Option on Open Units
- Factory Loadbank Tested
- Mainline Circuit Breaker
- Skid Mounted
- Generator Type: Gas
- Digital Control Panel
- Sound Attenuated Weather Proof Enclosure - Available as Option on Open Units
- Export Only
- 50 Hertz

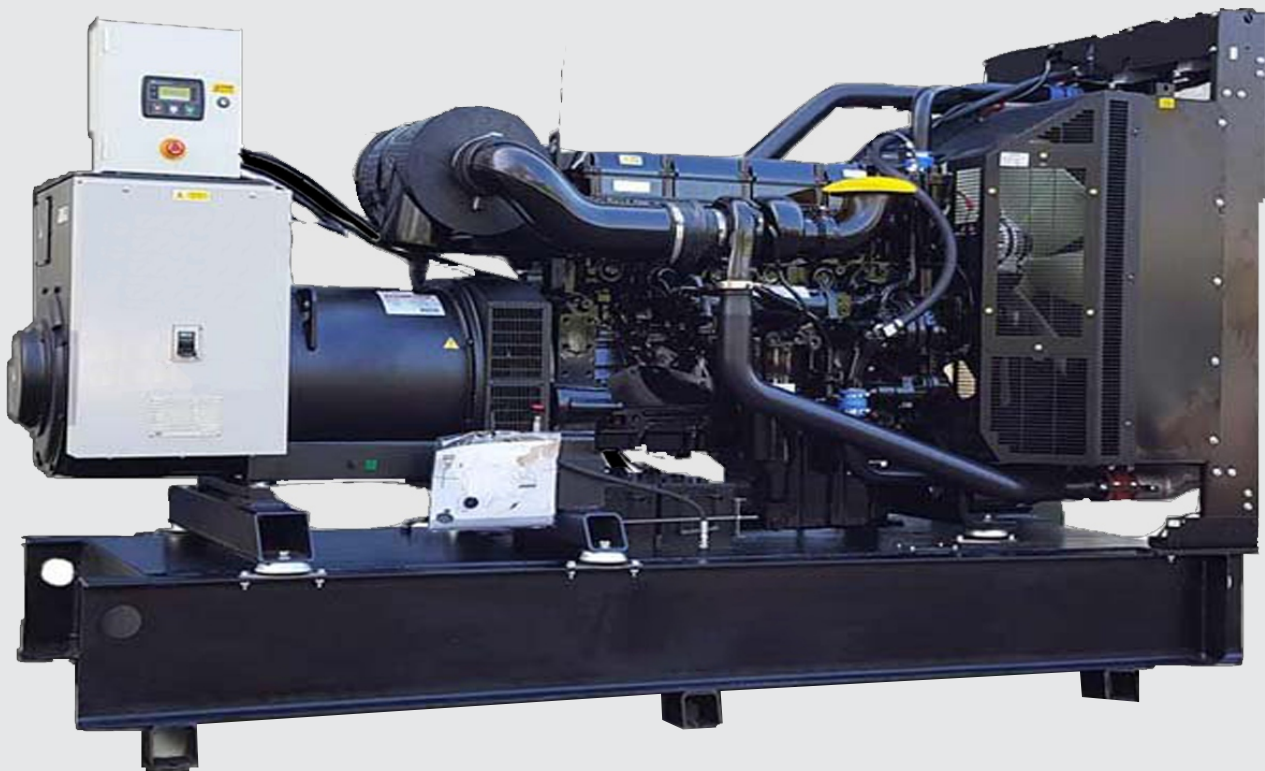

GENERAL DATA

Available Voltage	Standby	kVA	450
3 Phase		kW	360
220/380 Volt , 50 Hz	Prime	kVA	400
Power Factor 0.8		kW	320

Standby : Continuous running at variable load for duration of an emergency. No overload is permitted on these ratings. in accordance with ISO 3046.

Prime : Continuous running at variable load for unlimited periods with 10% overload available for 1 hour in any 12 hour period. In accordance with ISO 8528 , ISO 3046

- High quality, reliable and complete power unit
- Compact design
- Easy start and maintenance
- Every generator set is subject to a comprehensive test program which includes full load testing and checking and providing of all control and safety shut down functions testing
- Full engineered with a wide range of options and accessories :
 - Sound Attenuated Enclosure
 - Permanent Magnet Generator
 - Electronic Governor

Available for voltages :

400/230V, 480/277V, 380/220V, 440/254V, 416/240V, 220/127V, 208/120V

All datas based on ISO 3046, altitude 100m (328ft), barometric pressure 100kPa (29.53inHg), air temperature 25 relative humidity 30%.

Please contact with engineer for correct generator capacity selection when the load application can't meet with the standard reference.

Gas generators comply with standards :

ISO8528,ISO 14000,ISO3046,GB755,BS5000,VDE0530,IEC34-1

ENGINE INFORMATION

ENGINE MAKE		PERKINS
Model		NW 450-400 kVA
Engine Speed		1500
Tier Rating		Tier 1
Engine Power Output at rated rpm	kWm	600
	HP	510
Cooling		Radiator Cooled
Aspiration		Turbo charged & Air to Water charge Cooled
Total Displacement	Litre	35.735
No. of Cylinders and Build		6 Vee Form
Bore and Stroke	mm x mm	160 x 190
Compression Ratio		16.3.1
Governor		Electronic
Gas Consumption (L/hr)	Full Load	180
	75% Load	135
	50% Load	90
Gas Tank Capacity (Non-UL)	Litre	320 SAE
Oil Capacity	Litre	120
Coolant Capacity	Litre	100
Radiator Capacity Air	m ³ /min	1320

Economic Power

- Mechanically operated unit gas injectors with electronic control, combined with carefully matched turbo charging, provide excellent gas economy and low emissions.

Compact, Clean and Efficient Power

- Exceptional power to weight ratio and compact size give optimum power density for ease of installation and more cost effective transportation
- Designed to provide excellent service access for ease of maintenance

Reliable Power

- Developed and tested using the latest engineering techniques and finite element analysis for high reliability, low oil usage and low wear rates.
- High compression ratios ensure clean rapid starting in all conditions.

Product Support

- total worldwide service is provided through a network of 4000 distributors and dealers.
- TIPSS -The Integrated Parts and Support System enables customers to specify and order parts electronically.

ALTERNATOR INFORMATION

Manufacturer	Noxel - N252X
Design	Brushless single bearing, revolving field
Stator	2/3 pitch
Rotor	Single bearing, flexible disc
Insulation System	Class H
Standard Temperature R _{se}	125 - 163°C Continuous
Exciter Type	Self Excited
Phase Rotation	A (U), B (V), C (W)
Alternator Cooling	Direct drive centrifugal blower fan
AC Waveform Total Harmonic Distortion	No load < 1.5% Non distorting balanced linear load < 5%
Telephone Influence Factor (TIF)	< 50 per NEMA MG 1-22.43
Telephone Harmonic Factor (THF)	< 2%

STANDARD ITEMS

- Mainline Circuit Breaker
- Generator Set mounted on Heavy Duty Steel Base Frame
- Anti-Vibration Pads between Engine/Alternator and Frame
- Forklift Pockets within Base Frame (up to 1000 kW)
- Battery Charging Alternator

OPTIONAL ITEMS

ENGINE OPTIONS	<ul style="list-style-type: none"> • Engine Block Heater • Racor Water Separator • Oil Heater
ALTERNATOR OPTIONS	<ul style="list-style-type: none"> • Permanent Magnet Generator • Anti-Condensation Heater • Oversized Alternator (Motor starting)
OTHER OPTIONS	<ul style="list-style-type: none"> • Sound Attenuated Enclosure with Critical Silencer (70 db at 7 meters) • Trailer (with or without Gas Tank) • UL-142 Base mounted Gas tank • Residential or Critical Grade Silencer

CONTROL SYSTEM INFORMATION

MODEL : DSE 6020

Main Feature :

Electronic J1939 (CAN) and nonelectronic MPU and alternator sensing engine support for diesel, gas and petrol engines all in one variant. With a number of flexible inputs, outputs and protections, the modules can be easily adapted to suit a wide range of applications.



Key Functions :

- ▲ Utility voltage sensing
- ▲ Configurable staged loading outputs
- ▲ Configurable remote start input
- ▲ Generator/load power monitoring (kW, kV A, kV Ar, pf)
- ▲ CAN, MPU and alternator speed sensing in one variant
- ▲ Alternative configuration
- ▲ Alarm including common alarm, common electric and common shutdown
- ▲ Generator overload protection (kW)
- ▲ 3 engine maintenance alarms
- ▲ Efficient power save mode
- ▲ Engine speed protection
- ▲ LCD and LED alarm indication
- ▲ Mains and generator closed via front panel
- ▲ Engine pre-heat
- ▲ Configurable event log (50)
- ▲ Multiple date and time scheduler
- ▲ Heated display option available
- ▲ 4 configurable DC outputs
- ▲ Engine idle control for starting & stopping
- ▲ 4 configurable analog./digital inputs
- ▲ 6 configurable digital inputs
- ▲ Gas pump control
- ▲ Support for 0-10 V & 4-20 mA oil pressure sensors
- ▲ Battery voltage monitoring
- ▲ Start on low battery voltage

☆For more information, please visit the official website

WEIGHT AND DIMENSIONS

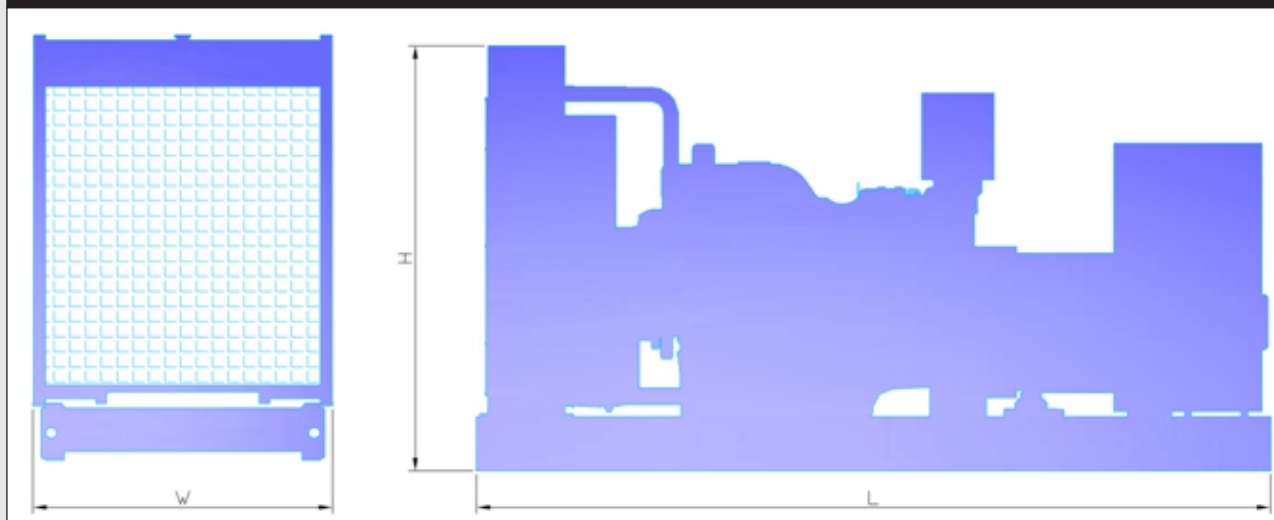

SKID MOUNTED GENERATOR

DIMENSIONS (LxWxH)	mm	3200 x 1200 x 1850
DRY WEIGHT	kg	4120

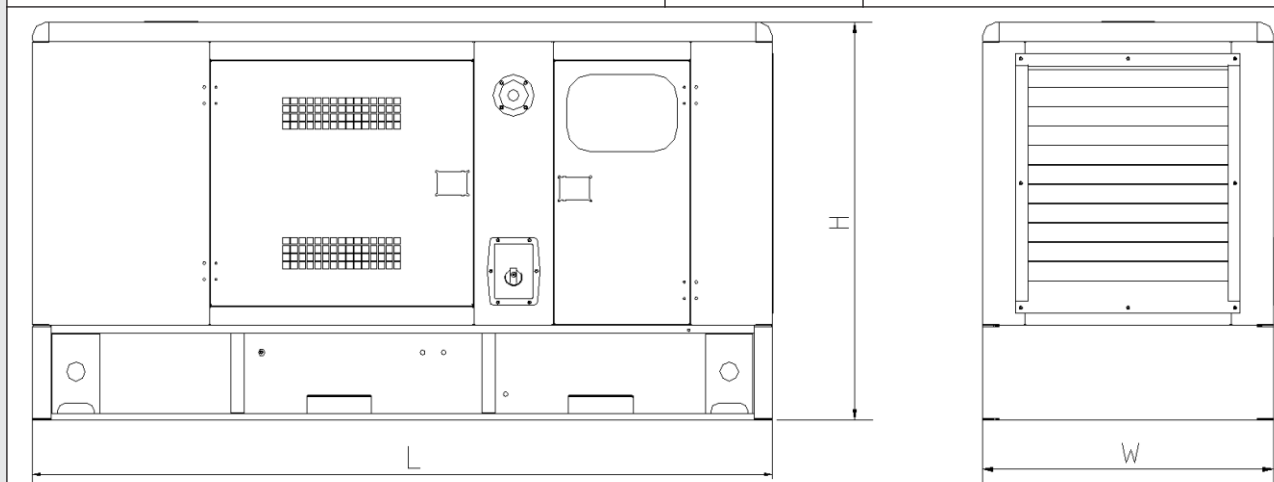

SOUND ATTENUATED GENERATOR

DIMENSIONS (LxWxH)	mm	4200 x 1500 x 2100
DRY WEIGHT	kg	4900

FEATURES AND BENEFITS OF ENCLOSURE :

- All enclosure parts are modular
- No welding to reduce corrosion
- Doors on both sides for easy maintenance
- All metal parts are powder coated
- Critical Exhaust Silencer Included
- Thermally insulated exhaust system
- Emergency stop located on exterior
- Easy Lifting and Moving

GAS GENERATOR

POWERED

BY

NOXEL

WITH

 **Perkins**

ENGINE